



Carriers

6600 - 11000lbs

Excavators

Screening Area

17 inches x 32 inches

Weight

630lbs

Capacity

0.24yd³

Flow

14.5 gpm/us

Dimensions

A - 17 inches D - 42 inches

B - 32 inches E - 30 inches

C - 21 inches F - 26 inches

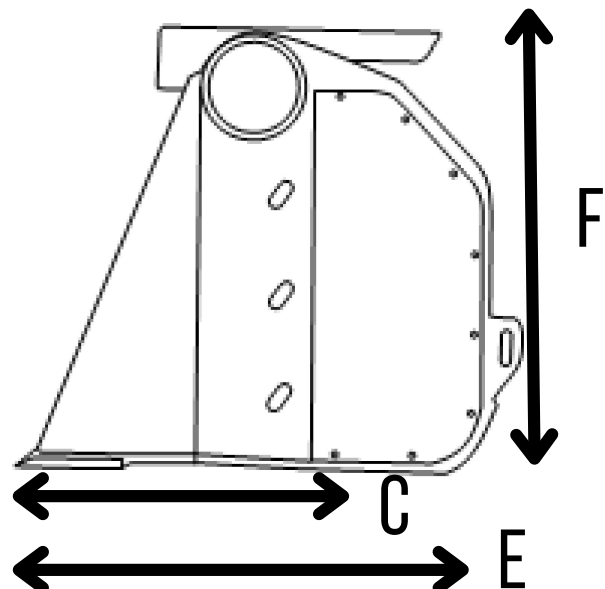
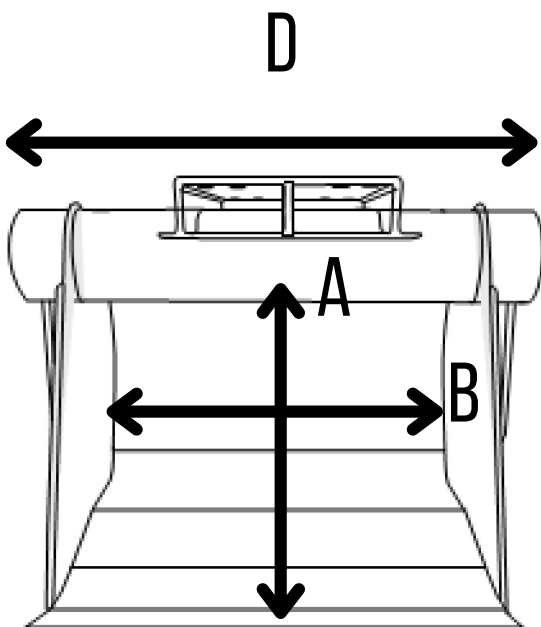

True Compact Screening
Low maintenance System
Poly-Stars screen without crushing
Non-stick floor as standard